

## FITTING INSTRUCTIONS FOR PRE 1971 TRIUMPH 650 c.c. UNIT TWINS

### Dismantling

Remove the battery. Take off all the wiring connectors from the coils and condensers. Remove the contact breaker plate assembly and the advance/retard unit.

### Assembly

N.B. These instructions assume originality and a certain amount of improvisation may be needed to make all the components fit properly.

Mount the amplifier by drilling 2 x  $\frac{1}{4}$ " holes in the rear mudguard below the battery carrier.

Note The amplifier will not work correctly unless the aluminium case is earthed.

Pass the amplifier harness up to the coils avoiding sharp edges and rubbing points. The battery can now be replaced, but do not connect up until the wiring is completed.

Screw the Pickup Backplate onto the engine in the middle of its adjustment slots, in the position shown in the diagram. Fit the Reluctor into the camshaft taper and set the 0.2-0.3 air gap. Note that it is unnecessary to slacken the pivot screw to adjust the air gap; only slacken the clamp screw on the slotted hole in the pickup.

Set the engine on the fully advanced timing marks and turn the backplate to trap the 5 mm timing spacer as shown.

### Wiring

The wires from the RITA amplifier are prepared with end connections to plug in to the original wiring removed from the coils and condensers. Since the original connections are not all required for the RITA circuit, it is necessary to insulate the end of the female Lucars that are not required in order that they do not short to earth on the frame.

Therefore tape over the single female lucar on the white-yellow. Connect the amplifier wires as shown on the diagram, i.e. black to double white-yellow (or white-blue on some models). Tape round the joint of the plastic sleeves to avoid them pulling apart. Connect the wiring as shown in the diagram ensuring the wires are not trapped or liable to chafe.

Run the engine and adjust the fully advanced timing position using a stroboscope. A flash reading at 6,500 RPM is necessary as there is a slight increase in advance all the way up the range of RPM.



**BRITISH CYCLE SUPPLY**

Call (902)542-7478

Fax (902)542-7479

[info@britcycle.com](mailto:info@britcycle.com)

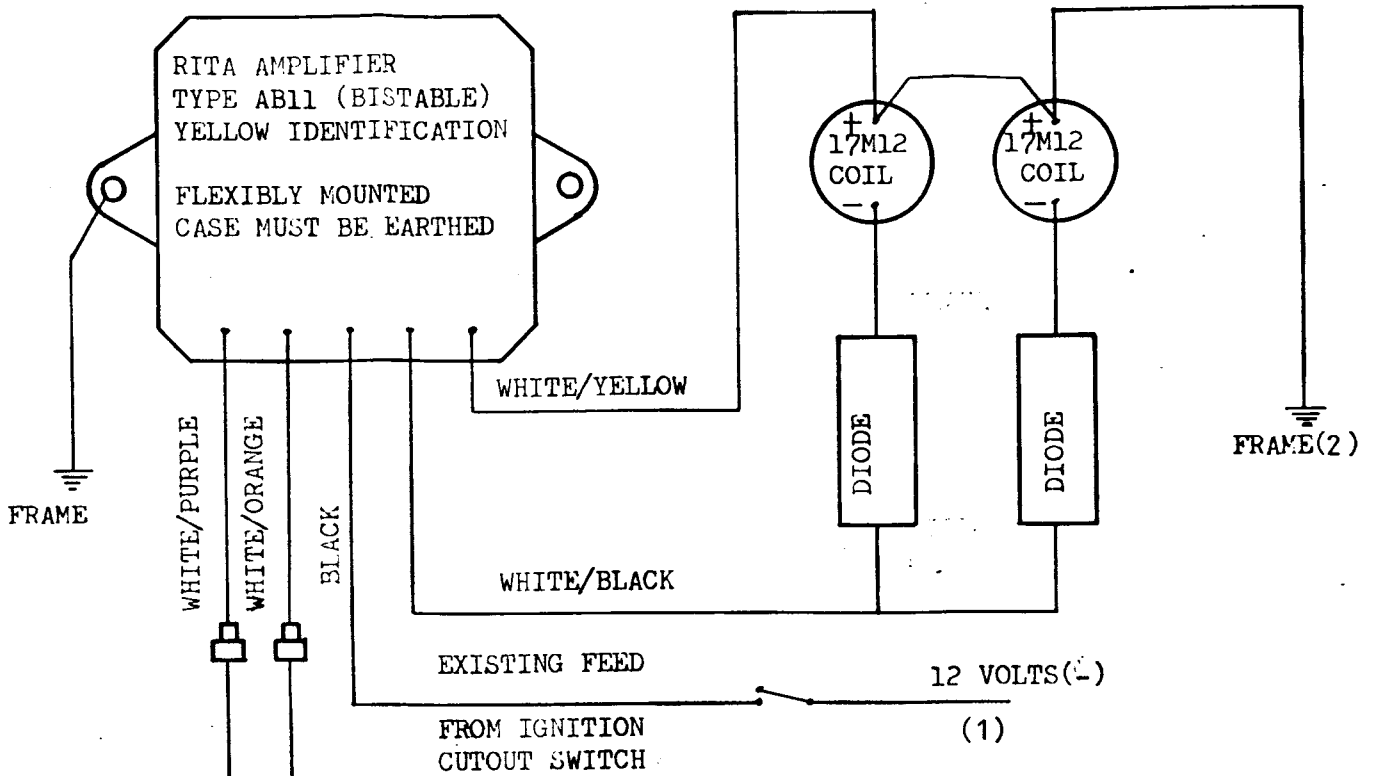

**BRITISH CYCLE SUPPLY**

Call (902)542-7478

Fax (902)542-7479

[info@britcycle.com](mailto:info@britcycle.com)

NOTE THE AMPLIFIER CAN BE DAMAGED IF THE H.T. VOLTAGE DOES NOT GO TO EARTH. THEREFORE DO NOT EXCEED A 5MM AIR GAP IF TESTING COIL OUTPUT.

BLACK/WHITE  
(EX. CONTACT BREAKERS)  
BLACK/YELLOW

0.2-0.3MM (.008"-.012")  
RADIAL CLEARANCE  
CHECK 2 POSITIONS

**BRITISH CYCLE SUPPLY**

Call (902)542-7478

Fax (902)542-7479

[info@britcycle.com](mailto:info@britcycle.com)

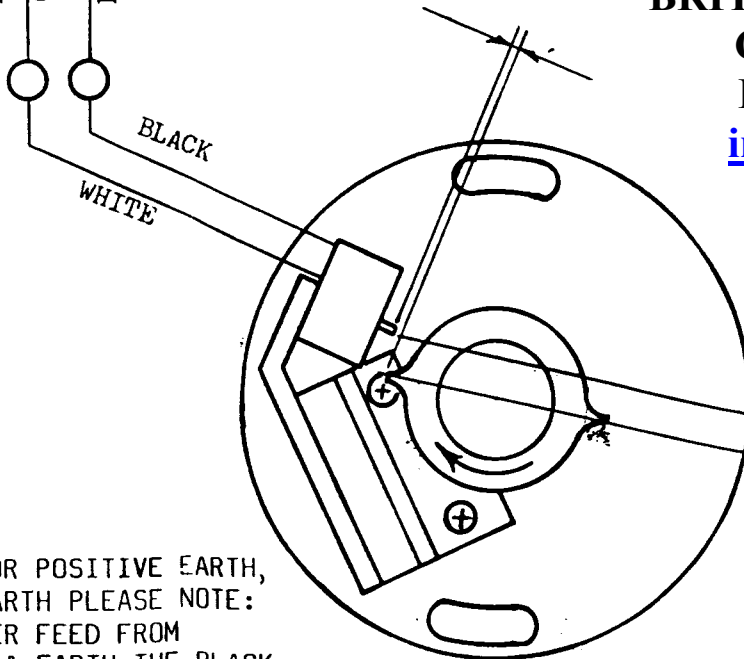

WIRING SHOWN FOR POSITIVE EARTH,  
FOR NEGATIVE EARTH PLEASE NOTE:

- (1) REMOVE POWER FEED FROM BLACK WIRE & EARTH THE BLACK
- (2) REMOVE EARTH LINK FROM COIL POSITIVE & REPLACE WITH 12V. POWER FEED FROM SWITCH