

APPLICATIONS

- TRIUMPH TRIDENT (T150/T160) / BSA ROCKET 3 / HURRICANE (X75) 12 VOLT
- CLOCKWISE TIMING DISC ROTATION

FEATURES

- HIGH-POWER RE-PROGRAMMABLE DIGITAL IGNITION MODULE (FULLY ENCAPSULATED)
- FULLY MAPPED IGNITION TIMING & PROGRAMMED COIL ENERGY CONTROL
- USER-PROGRAMMABLE REV.LIMITER BUTTON
- RELIABLE & RUGGED HALL-EFFECT SENSOR , INCLUDES ON-BOARD STATIC TIMING LIGHT, FOR EASY SETTING OF IGNITION TIMING
- MINIATURE HIGH-ENERGY IGNITION COILS
- WASTED SPARK SYSTEM FOR SIMPLICITY
- LESS MAINTENANCE
- IMPROVED ENGINE PERFORMANCE
- FOR RACING OR HIGHLY TUNED APPLICATIONS: SPECIAL ADVANCE CURVES & REV-LIMITERS AVAILABLE
- COVERED BY MANUFACTURER'S FIVE-YEAR WARRANTY
- MODULE SIZE(mm):
90 LONG x 65 WIDE (95 INC. MOUNTING BRACKETS)
x 30 DEEP, WEIGHT: 400g (INC. WIRES)

IGNITION SYSTEM COMPRISES:

- IGNITION MODULE (ALUMINIUM HOUSING WITH MOUNTING BRACKETS) & WIRING
- DIGITAL HALL-EFFECT TRIGGER UNIT
- STEEL TIMING DISC, 1/4" FIXING BOLT (UNF) & WASHER
- DIGITAL IGNITION COILS (ONE SINGLE OUTPUT & ONE DUAL OUTPUT)
- H.T. LEADS (COPPER-CORED)
- PLUG CAPS (5K RESISTOR TYPE)
- FIXING SCREWS, WASHERS & NUTS (FOR MODULE & COILS)
- CRIMP TERMINAL CONNECTORS & INSULATORS
- BLACK COIL LINK WIRE
- YELLOW-GREEN EARTHING WIRE
- LARGE & SMALL CABLE TIE-STRAPS

FITTING INSTRUCTIONS

**WARNING: THIS SYSTEM PRODUCES VERY HIGH VOLTAGES,
ALWAYS SWITCH OFF BEFORE WORKING ON THE SYSTEM.**

IMPORTANT NOTES:

BEFORE FITTING, PLEASE READ THESE INSTRUCTIONS CAREFULLY, INCLUDING THE NOTICE ON PAGE 16.

This system is designed to work only with the special digital ignition coil provided with the system. 5K resistor plug caps as supplied with the system should be fitted to the h.t. leads. Alternatively, resistor spark plugs can be used. Resistor plugs & resistor caps can be used, although it is not necessary to use both. Attempting to run the system without resistor type caps or plugs will result in excessive radio frequency interference (r.f.i.), which may cause bad running, misfiring and loss of ignition. For reliability, copper or steel cored h.t. lead should be used, we do not recommend using carbon fibre leads. This ignition is a wasted spark system, therefore all plugs fire at the same time.

These instructions are a general guide for installing the system to various machines and therefore it may be necessary to modify the length or routing of some wires in order to complete the installation. All connections should be made using good quality crimped or soldered connections; twisted wires will not give satisfactory operation. wiring should be trimmed to the correct length, excess wire should not be coiled up as this can affect the correct running of the ignition system. If electric welding is to be carried out, the ignition module should be disconnected and its connectors covered with insulation, to help prevent stray sparks from damaging the module. If in doubt, remove the unit from the machine.

1. All connections must be of the highest quality, use crimped or soldered connections; twisted wires will not give a satisfactory operation.
2. Open the seat to gain access to the ignition coils.
3. Remove the left hand side battery cover.
4. For safety, disconnect the battery by removing the fuse from the negative battery terminal (positive terminal if the electrics are negative earth).
5. Undo the contact-breaker cover and remove the contact-breakers and backing plate. Disconnect the three wires.
6. Remove the complete auto-advance unit. If stuck, this can be removed from its taper by using a puller or by inserting a small piece of steel rod down the centre and tapping it around until it frees from the taper.
7. Disconnect and remove the black-red, black-white & black-yellow wires from the ignition coils and condensers. These wires run through the wiring harness down to the contact-breaker housing and are no longer required. The condensers are no longer required and can be removed. They should not be connected to the electronic ignition system.
8. Remove the white-yellow wires from the negative terminals of the three ignition coils (positive terminals if negative earth electrics).
9. Remove the three original ignition coils; if the coils are stuck in their mountings, apply penetrating oil and, by removing the battery, the coils can be reached from below and worked out.
10. Fit the new ignition coils, either in place of the original coils or suspended from the frame in a convenient place. Suspend the coils by the two mounting lugs, using the M5 bolts, washers & nuts. Alternatively, to avoid the need for drilling or a mounting bracket, each coil can be rubber mounted using two small pieces of rubber tubing (such as fuel pipe or heater hose) & two large tie-straps, see figs. 1 / 1a. The coils can then be secured to the frame tube by fully tightening the tie-straps. Fit the new h.t. leads by pushing the brass connectors fully into the h.t. outlets of the coil, along with the rubber boots. Small tie-straps can be placed around the rubber boots & tightened to give extra security, if desired. The h.t. leads should now be cut to length, if necessary, & the plug caps screwed onto the ends of the h.t. leads. Push the plug caps onto the plugs; the dual output coil feeds the left & right plugs (either way around) and the single output coil feeds the centre plug.

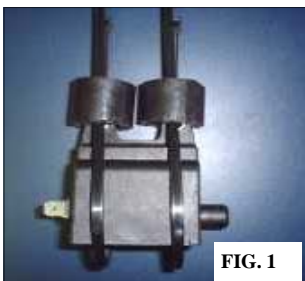

11. Fit the ignition module in a convenient place. This could be under the battery platform or secured to the frame using a suitable mounting bracket. The unit can be orientated in any position, but this should be onto a flat surface, if possible. the module can be secured by the mounting flanges using two M5 bolts, washers & nuts. Alternatively, the mounting flanges can be removed by slackening the bracket securing screws and sliding the brackets out of the dovetail slots. The module can then be mounted using large tie-straps, with a small sheet of rubber between the case & the frame. The module casing acts as a shield for the internal electronics, therefore it is recommended that the case is connected to the frame. This can be achieved by direct contact between the mounting brackets & screws, but if the mounting surface is non-metallic, plastic-coated or not connected directly to the frame, then an earthing wire should be provided. This would be a short wire with a ring/fork terminal at one end (placed under one of the mounting screw heads or nuts, or under the head of one of the module end plate screws) and a ring terminal at the other end connected to the frame earth. A short yellow/green wire is provided for this.
12. Remove the timing side spark plug, turn the engine over until compression is felt by placing a finger over the plug hole.
13. Remove the triangular timing inspection plate to expose the alternator rotor.
14. Slowly rotate the engine forward until the first timing mark is aligned with the reference pointer. This is the full advance timing mark (38° B.T.D.C.), which is identified in the Owners Manual. The right-hand cylinder is now at the full advance timing position. The timing marks on the alternator are 120° apart, but only every 240° is any one cylinder on compression, thus it is possible to set the ignition to fire on a timing mark but off compression.
15. Fit the timing disc into the taper from which the auto-advance unit was removed with the holes positioned approximately as shown in fig. 2 (PAGE 12), using the ¼" washer and the UNF bolt provided. Tighten the bolt with a 3/16" allen (hex) key. Recheck the timing disc position. The centre thread (metric M8) is provided for attaching a puller, if the timing disc should need to be removed for engine servicing.
16. Take the ignition trigger assembly (round green printed circuit board) & pass a small tie-strap through the set of holes in front of the 4-way connector block; leave unfastened at this stage. Fit the trigger assembly (connector block facing outwards) into the contact-breaker housing with the original pillar fixings; finger tighten so that the trigger can be turned by hand.

WIRING (SEE WIRING SCHEMATICS ON PAGES 8 & 9)

1. The ignition trigger wires (sleeved) are coloured white—red, violet—red, white—black, & yellow-green. Allowing some slack in the cable (for ignition timing adjustment), route these wires from the ignition module down to the trigger in the points housing. If passing through holes in metalwork, use grommets or sleeving. Cut the trigger cable & sleeving to length. Route the sleeved wires to the trigger connector block. Carefully strip back a small amount of insulation (4-5mm) from the ends of the four wires. Insert the wires into the connector block on the trigger in order (from left to right):
white—red, violet—red, white—black & yellow-green. Tighten the terminal screws. Secure the sleeved wires to the trigger plate by fastening the tie-strap inserted earlier; cut off the excess from the tie-strap.
2. Using the black coil link wire (supplied), connect the positive (+) terminal of coil #1 to the negative (—) terminal of coil #2.
3. Take the violet wire from the ignition module, cut to length and fit an insulator and female spade connector to the end. Connect to the negative (—) left-hand terminal on ignition coil #1 (single output coil).
4. Take the red wire from the ignition module, cut to length and fit an insulator and female piggyback spade connector to the end. Connect to the positive (+) right-hand spade terminal on ignition coil #2 (dual output coil).

***Re-check the connections to the ignition coils;
reverse polarity may damage the coils.***

For **NEGATIVE EARTH** electrics go to step 6.

5. For **POSITIVE EARTH** electrics (**standard**):
 - Remove the red wire going to the earthing terminal on the condenser unit. Reconnect this red wire to the spare piggyback spade connector on the positive (+) right-hand spade terminal of ignition coil #2 (dual output coil). See page 9.
 - Take the black wire from the ignition module, cut to length and fit an insulator and male spade connector to the end. Connect to any one of the three white-yellow wires previously removed from the ignition coils in step 8 (page 4). An in-line fuse can be fitted here (8-10 amp recommended). The other white-yellow wires are spare and should be covered with insulation to prevent shorting to the frame etc. See page 9.
 - **GOTO STEP 7.**
6. For **NEGATIVE EARTH** electrics:

- Connect one of the positive ignition feed wires previously removed from the ignition coils in step 8 (page 4) to the positive (+) right-hand spade terminal of ignition coil #2. An in-line fuse can be fitted here (8-10 amp recommended). The other wires are spare and should be covered with insulation to prevent shorting to the frame etc. See page 8.
 - Take the black wire from the ignition module, cut to length and connect to a good earth point, either to the earthing terminal on the condenser unit or fit a ring terminal connector to the end and connect to a good earth point on the frame, ideally the battery negative (—) terminal. See page 8.
7. The ORANGE wire is an IGNITION INHIBIT input, and only functions with NEGATIVE EARTH electrics.
This can be connected to a grounding kill switch or a hidden security switch. If not required, place insulating tape over the end of the wire to prevent accidental shorting out.
 8. The GREY wire is a tacho output signal for driving an electronic tachometer, if fitted. This is a 12 volt output and provides 1.5 pulses per engine revolution (or 3 pulses per 2 engine revolutions). If your tacho requires a different pulse rate, contact Pazon Ignitions. Connect to the tacho signal input terminal/wire. If you have a mechanical tacho (or no tacho) then leave unconnected and insulate the wire end.
 9. Any remaining wires present on the ignition module are for factory use and should remain unconnected and insulated, as supplied.
 10. Refit the fuse / reconnect the battery.
 11. GOTO **TIMING** SECTION ON PAGE 10.



WARNING: TURN OFF/DISCONNECT THE BATTERY BEFORE WORKING ON THE SYSTEM HIGH VOLTAGES CAN KILL

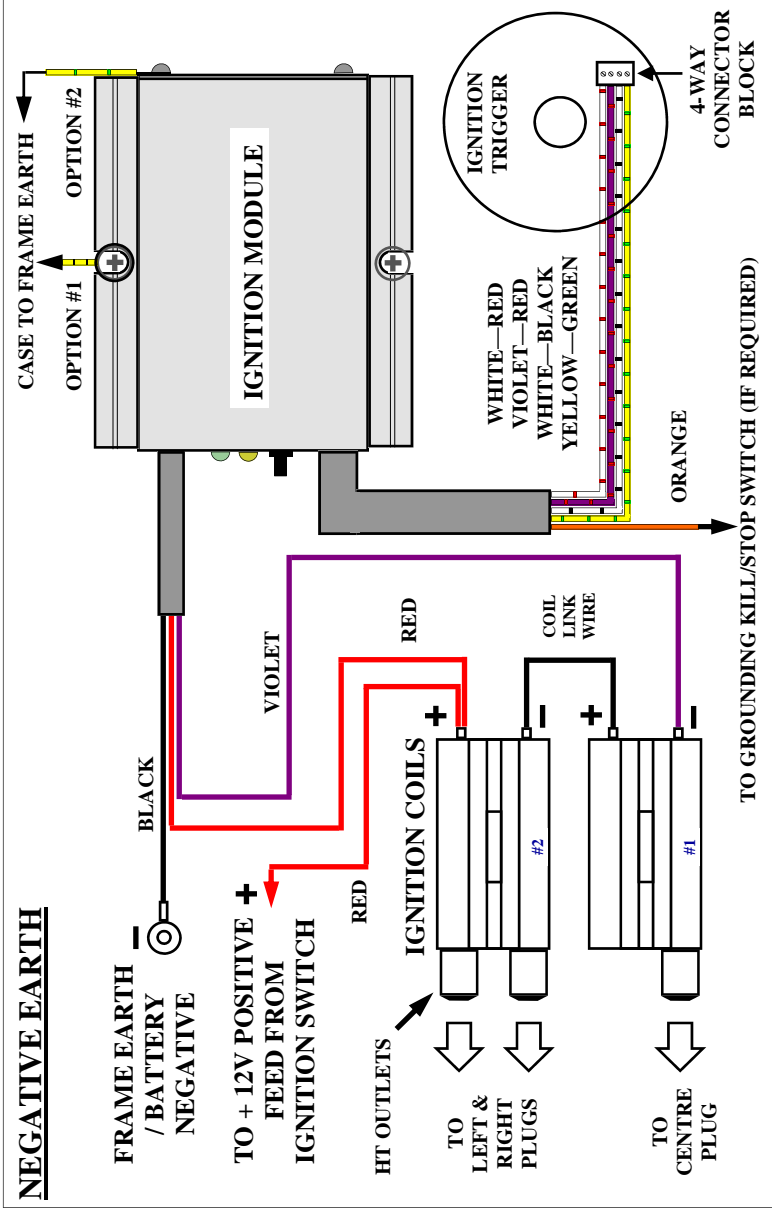



WARNING: TURN OFF/DISCONNECT THE BATTERY BEFORE WORKING ON THE SYSTEM HIGH VOLTAGES CAN KILL

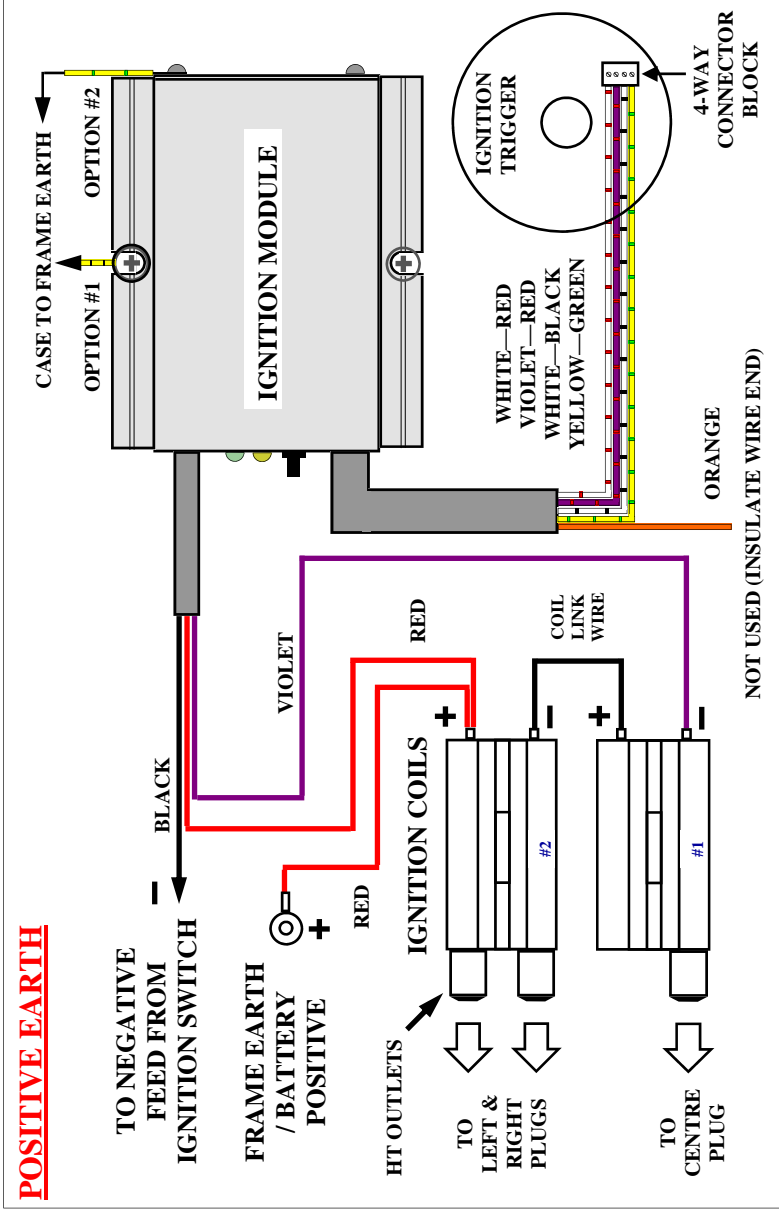

TIMING (see figs. 4-7, page 13)

1. Switch off ignition.
2. If necessary, slightly loosen the ignition trigger fixings so that it can be rotated by hand. Position the trigger plate in the fully clockwise position. See fig. 4, page 13

Warning: risk of electric shock, keep hands & body away from coil, ht leads, caps & plugs

3. The following operations may produce a spark from the plugs, therefore it is recommended that the spark plugs be removed and grounded onto the cylinder head (with the plug caps & h.t. leads connected to them). Alternatively, the violet wire can be temporarily removed from the negative terminal of ignition coil #1, place insulating tape over the end of the connector to prevent shorting to earth. This will prevent any undesired sparks whilst timing.
4. (Reconnect the battery).
 - a) Switch the ignition on, the small green light on the ignition module should turn “on”.
The red static timing light on the trigger should turn “on”
 - b) Turn the trigger plate fully anti-clockwise.
See fig. 5 on page 13
 - c) Turn the trigger plate fully clockwise (back to start position).
The red timing light should now be “off”. See fig. 6 on page 13
 - d) Finally, turn the trigger plate slowly anti-clockwise until the red timing light turns “on”; STOP TURNING. This is the timing point for full advance. See fig. 7 on page 13
 - e) Keeping the trigger in position, tighten the fixings.
 - If you make a mistake, switch the ignition off and restart from the beginning of step 1.
 - Note the final position of the lower left timing hole visible through the inspection window.
 - If you make a mistake, switch the ignition off and restart from the beginning of step 1.
 - If the timing light does not turn on in step 4d, switch the ignition off, reposition the timing disc slightly further clockwise and restart from step 1.

5. Switch off the ignition.
6. Refit spark plugs, if removed earlier. Reconnect the violet wire to ignition coil #1, if disconnected in step 3.
7. If removed earlier, push the plug caps firmly onto the plugs, they should click into place.
8. Refit the battery cover, seat etc., as required. The engine should now start and after warming up should tick over well, provided everything else is correctly adjusted. The ignition will advance as per the pre-programmed advance curve (see graph on page 15).
9. The final timing can be checked and fine-tuned with a strobe timing light. The timing is adjusted by moving the trigger plate a small amount on its slotted holes. If desired, proceed as follows:
 - Warm engine for 4-5 mins.
 - Connect a xenon (white light) strobe lamp, preferably using a separate battery to power the strobe
 - All plugs fire at the same time (wasted spark system), therefore it does not matter which h.t. lead is used to trigger the strobe.
 - Time the engine to the full advance mark (the standard mark is at 38° btdc) with the engine running at 4000+ rpm
 - To advance the timing, rotate the trigger anti-clockwise
 - To retard the timing, rotate the trigger clockwise
 - Make very small adjustments; 1° of trigger movement equals 2° of crankshaft movement
 - The trigger has calibration marks on the outer edge to assist with timing adjustment
 - **For safety, switch ignition off between adjustments**
10. Refit the contact-breaker cover. The timing is now set for life. The system requires no maintenance, but satisfactory and reliable operation, the wiring, battery, coils, charging system, h.t. leads, plugs and carburettors must be maintained in good order.

POINTS HOUSING

FIG. 2

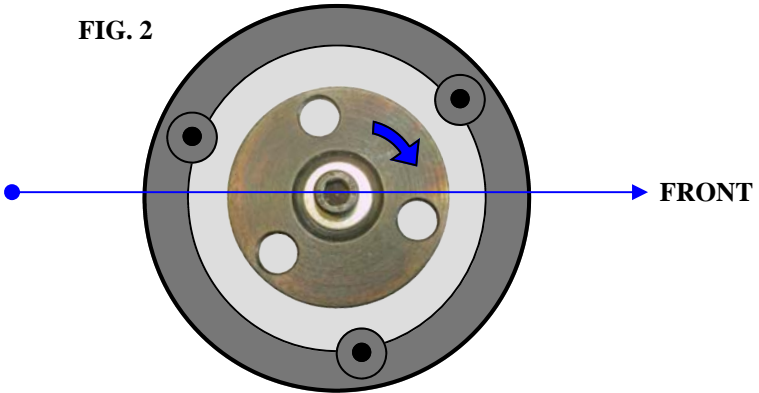

TIMING DISC
STATIC TIMING POSITION,
RIGHT HAND CYLINDER AT
FULL ADVANCE POSITION
ON COMPRESSION

DIGITAL TRIGGER UNIT

FIG. 3

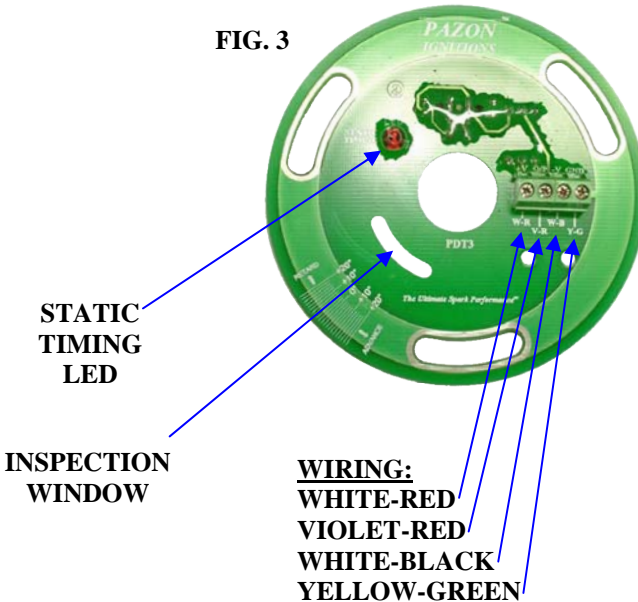

IGNITION TIMING
CLOCKWISE TIMING DISC ROTATION
(WIRING NOT SHOWN FOR CLARITY)

FIG. 4



START POSITION
FULLY CLOCKWISE.
IGNITION ON
RED TIMING LIGHT ON

FIG. 5

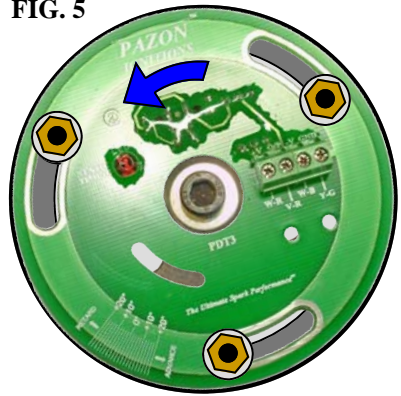

TURN FULLY
ANTI-CLOCKWISE

FIG. 6



TURN FULLY CLOCKWISE,
RED TIMING LIGHT
TURNS OFF,
TRIGGER IS NOW CALIBRATED

FIG. 7



TURN SLOWLY
ANTI-CLOCKWISE
UNTIL RED TIMING LIGHT
TURNS ON, STOP.
TIGHTEN TRIGGER FIXINGS

REV-LIMITER

USE OF THIS FUNCTION IS AT YOUR OWN RISK, SINCE IT IS POSSIBLE TO SET THE REV-LIMITER TO BEYOND THE DESIGNED UPPER RPM LIMIT FOR YOUR ENGINE.

The digital ignition module features a function button that enables the user to set/reset the ignition rev-limiter. Unless specified when purchasing the system, the rev-limiter is not preset, allowing your engine to rev to its maximum (unrestricted).

To set the rev-limiter

To accurately set the rev-limiter you will need a rev. Counter/tachometer to monitor the engine rpm. Rev the engine to one-half the desired rev-limit rpm, press & hold the function button for a minimum of 3 seconds. The ignition module will take a snapshot of the engine rpm at the instant the button is pressed, therefore it is not essential to maintain a precise rpm whilst the button is pressed. The yellow indicator led on the module will flash 5 times. Release the button. The rev-limiter is now set. When your engine reaches the preset rpm the ignition will turn off the ignition coil, cutting all sparks. Thus, the engine rpm will fall and, once below the rev-limit setting, ignition will resume.

The minimum rev-limiter setting is 3000 rpm (i.e. set with the engine running at 1500 rpm).

To reset the rev-limiter

To reset (disable) the ignition rev-limiter, press & hold the function button for a minimum of 3 seconds, with the engine below 1500 rpm (or stationary). The yellow indicator led on the module will flash 5 times. Release the button. The rev-limiter is now reset.

The rev-limiter setting is retained in the ignition module memory & will be recalled when the ignition is turned on.



DIGITAL IGNITION TIMING
TRIUMPH/BSA TRIPLE (ROAD)

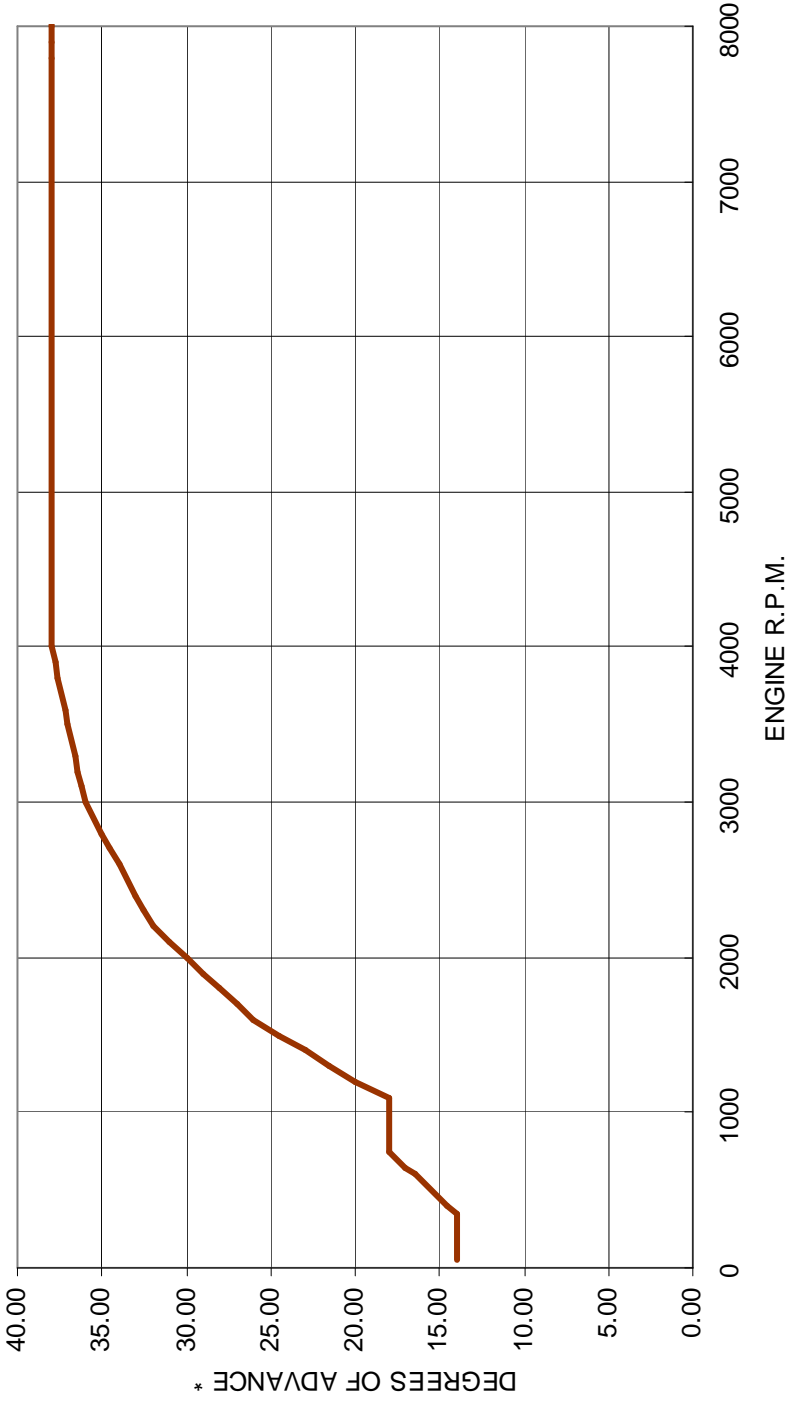

* RELATIVE TO STATIC SETTING

MAP017

Terms & Conditions and Warranty

- Use of this product indicates your acceptance of this notice.
- The product design & literature is Copyright © PAZON 2005, & is protected under international copyright, trademark & treaty provisions.
- To provide the best ignition systems possible, PAZON IGNITIONS reserves the right to alter & improve the specifications of its products without prior notice.

Ignition Systems

- Pazon warrants to the original purchaser that the Pazon Ignition System be free from defects in workmanship & parts under normal use for a period of five years from date of purchase.

Ignition Spares

- Spares are defined as item(s) not purchased as part of a complete ignition system. Pazon warrants to the original purchaser that these item(s) be free from defects in workmanship & parts under normal use for a period of one year from date of purchase.
- Ignition coils will only be covered by the warranty if it can be proved that the fault is due to a manufacturing fault within the coil.

Limitation of Liability

- In no event shall Pazon's liability related to the product exceed the purchase price actually paid for the product.
- Neither PAZON nor its suppliers shall in any event be liable for any damages whatsoever arising out of or related to the use or inability to use the product, including but not limited to the direct, indirect, special, incidental or consequential damages, or other pecuniary loss.
- This warranty will be void if the product or parts have been altered, damaged, abused or installed incorrectly.
- This warranty will be void if parts supplied by Pazon are used with other makes of ignition. Your statutory rights are not affected.

Warranty Claims

- To make a claim under warranty, the product must be returned to PAZON or its authorized representative, with a copy of your receipt (or evidence of date & place of purchase), within the warranty period.
- Include a detailed description of the problem and why you believe there is a fault within the ignition system.
- The system must be returned postage paid. Proof of posting is not proof or receipt, therefore we recommend using a recorded mail service.
- Upon receipt we will thoroughly test the returned items and repair or replace any items found to be faulty and covered by the warranty.
- Please allow seven working days from receipt of the returned parts before contacting us, to allow sufficient time for a thorough test and evaluation.
- PLEASE CONTACT PAZON IGNITIONS FOR RETURN INSTRUCTIONS.

✉ **PAZON, PO BOX 405, SITTINGBOURNE, KENT ME9 9WJ U.K.**

☎ **TELEPHONE: 08700 114858** 📠 **FAX: 08700 119868**

EMAIL: ignition@pazon.com WEB: www.pazon.com